

INSTALLATION, OPERATION,  
AND MAINTENANCE MANUAL

# DM-6000

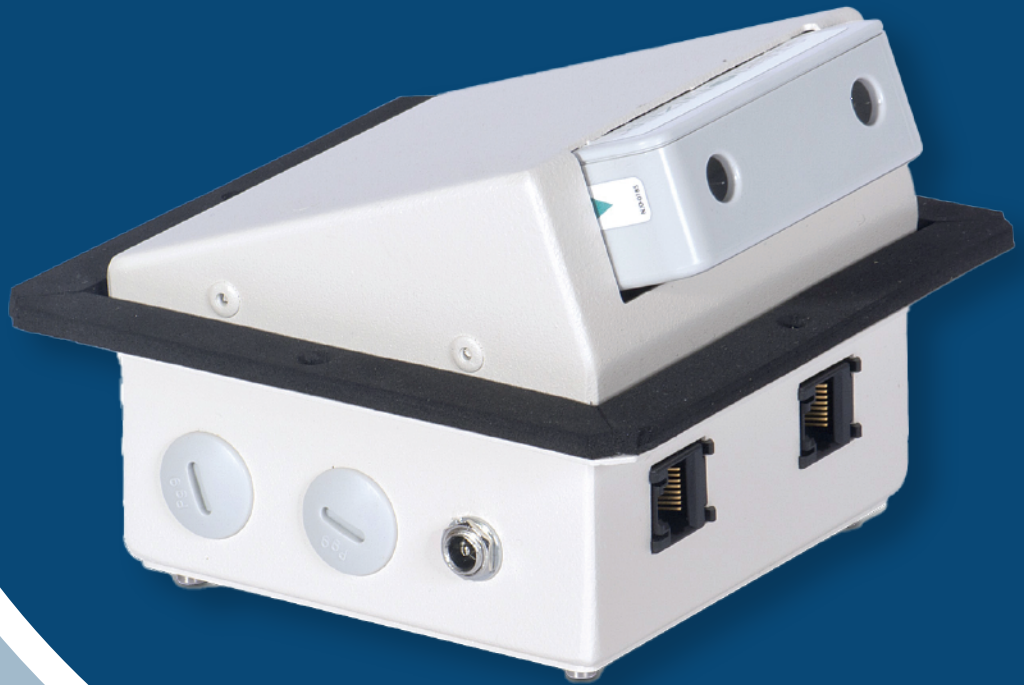

## GENERAL DESCRIPTION

The Air+ DM-6000 is an auto-cleaning, zero-ozone, needlepoint ionizer producing billions of positive and negative ions that deactivate bacteria and viruses, agglomerate particulate, and neutralize other harmful pollutants. No maintenance is required as the needles are cleaned of dirt and dust automatically and programmed from the factory at once per 24 hours of operation and upon start-up. The DM-6000 can be installed in the supply duct of any air handling system. The goal of the technology is to introduce ions to the airflow and have them delivered to the occupied space, so mount the DM-6000 as close to the supply diffusers as possible.

The unit can be powered with 12V or 24V, AC or DC, or a power supply can be provided for utilizing 120V or 240V AC power. The unit has communication capabilities including a dry contact and data export to the BMS. The DM-6000 provides an electronic signal only when the ionizer is creating ions. This signal is used to initiate a relay that closes the dry contact and powers the Ionization LED. The DM-6000 is UL2998 validated for zero ozone emissions.

## MECHANICAL INSTALLATION

**CAUTION:** The DM-6000 should not be installed immediately downstream of a humidifier or exposed to any moisture.

**CAUTION:** This product is intended for mounting into metallic construction only.

**CAUTION:** The DM-6000 shall not be installed behind an inaccessible suspended floor/-ceiling or a structural wall, ceiling, or floor.

1. The preferred location of the DM-6000 is in the supply air duct leaving the air handler. Be sure to pick a location before any branch duct take-offs and ensure access to all switches and power/communication input and data output terminals. To improve the effectiveness of the filter, the DM-6000 can be installed in the return duct upstream of the filter.
2. To mount the unit in a duct (See Figure 1):
  - a. Trace a 5 ½" by 5 ½" square on the surface of the duct onto which you are mounting the ionizer. The units have a gasket that forms a seal between the duct and the mounting flange.
  - b. Cut out the traced portion of the duct using snips or sheet metal shears.
  - c. Screw the DM-6000 onto the duct using sheet metal screws (See Figure 1).
3. Install the DM-6000 such that the ionizing needles are pointed downstream of the airflow. A directional arrow is located on the label to aid in unit orientation (See Figure 2).

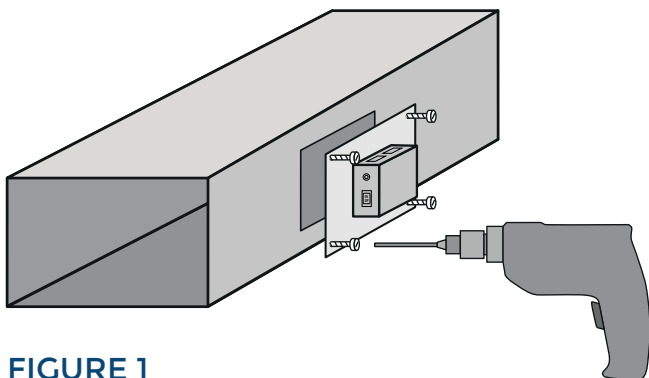

FIGURE 1

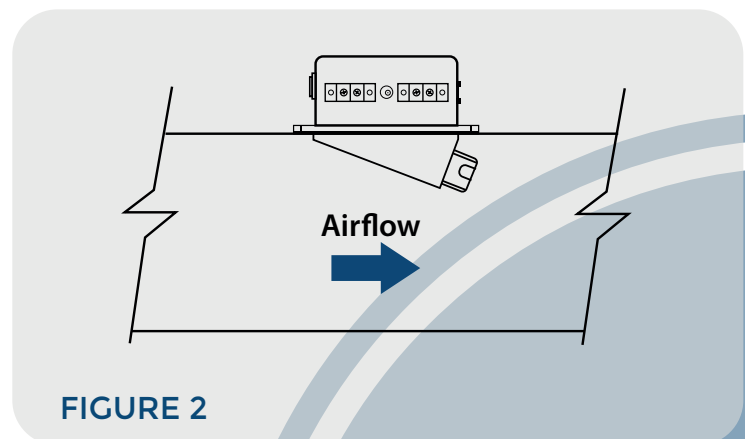

FIGURE 2

## ELECTRICAL INSTALLATION

**CAUTION:** Do not connect power to the DM-6000 before the installation is complete. Always disconnect power before handling any of the unit components.

**CAUTION:** Surge protection should be utilized for this product at the equipment or circuit feeding the ionizer. A transformer used to power the product must be grounded.

**CAUTION:** Do not power the ionizer from the same circuit or transformer to a UV Lamp.

1. Ideally, a dedicated 24V AC transformer be used to power the DM-6000. If this is not possible, power from a transformer serving other equipment may be used if sized adequately to handle the additional VA rating of the DM-6000. The power source should be protected by a circuit breaker not exceeding 20 Amps.
2. Power can be connected by either bringing 24V AC or DC directly to the terminal block on the unit or using a factory provided 120V/240V to 12V DC power supply (Air+ Part No. PS-Low). Connect 2.1mm pin to pin jack on the unit. (See Figure 3).
3. To communicate with the BMS, connect BMS wires to the terminal block on the outside of the unit. (See Figure 3).
4. Once power is connected to the unit, press the power switch to the "ON" position. The LED should illuminate. (See Figure 4).

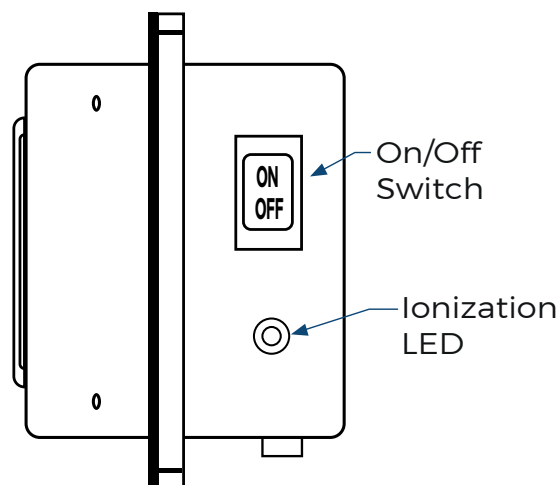
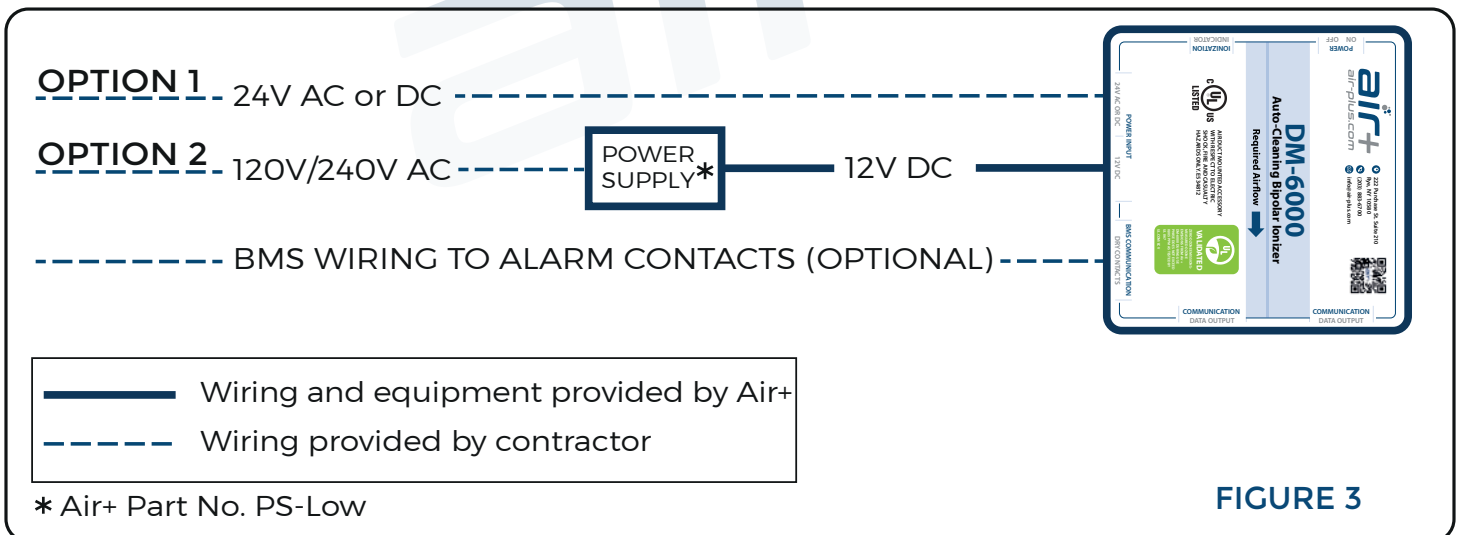

## BMS ALARM CONTACTS

The DM-6000 has an Alarm Circuit that communicates with the BMS. The Alarm Circuit utilizes a relay with normally closed contacts. The contacts are open whenever the unit is not powered or there is a fault in the system. When the DM-6000 is operating normally and producing ions, the contacts close and the Ionization LED on the outside of the unit will illuminate. Connect the BMS control wires to the BMS terminal block on the outside of the unit. (See Figure 3).

## OPERATION

1. When the power switch is turned "On", the DM-6000 will activate, the LED will illuminate, and the unit will produce ions. After about a minute, the self-cleaning mechanism will run through a complete cleaning cycle and the unit will produce ions again (See Figure 4).
2. Because the DM-6000 is self-cleaning, no maintenance of any kind is required. The cleaning cycle is factory programmed to initiate every 24 hours and upon start-up.

## TROUBLESHOOTING

1. If the DM-6000 is not operating, check that the power switch is set to the "On" position and the Ionization LED is illuminated.
2. Confirm that all power wiring is connected properly to the terminal block on the outside of the unit. Test the BMS Dry Contacts using a multimeter set to continuity mode. If the multimeter alarms, the circuit is continuous, and operation is confirmed. If it does not alarm, the circuit is not continuous and there is a problem. Contact Air+ customer support as needed.
3. The DM-6000 has an internal automatically resetting fuse. If the fuse trips, remove power by turning the power switch off, wait 2-5 minutes for the fuse to reset and turn power back on. If the fuse trips again, contact customer support.

