

INSTALLATION, OPERATION, AND MAINTENANCE MANUAL

100/200 SERIES

(101C, 101D, 101E, 102C, 102D, 102E, 103C, 103D, 103E, 201D, 201E, 202D, 202E)



air+
air-plus.com

©2026 Air+ Rev1 3/26



INTRODUCTION

The Air+ 100 series and 200 series ion generators are single tube and double tube commercial quality equipment that can be installed in air handling units (AHU), roof top units (RTU) or duct systems for residential, commercial, and industrial applications. The units are effective in reducing harmful pathogens and odors by introducing positive and negative ions into the system airflow. The number and length of the ionization tubes is dependent on the airflow in the system and the severity of the pollutants in question. See chart on the back of this manual for selection criteria.

MECHANICAL INSTALLATION

WARNING: To reduce the risk of fire, this unit should not be installed downstream of a humidifier or exposed to other sources of moisture.

CAUTION: This product is suitable for mounting into duct of metallic construction only. Installation must be such that the structural integrity of the ducting is not compromised.

CAUTION: Mount units to provide access to the ionization level control knob, fuse, and for tube replacement. This product shall not be installed under a suspended floor or behind a structural wall, ceiling, or floor.

CAUTION: This product should not be mounted in a location where the air temperature exceeds 150° F. This typically means that it should not be installed at the outlet of a gas or oil-fired furnace.

Step 1. The preferred location is in the supply air duct leaving the air handler. Be sure to pick a location before any branch duct take-offs. Verify that there is sufficient duct depth to allow clearance for the tube. C-Tube = 6"(L), D-Tube = 10"(L), E-Tube = 14"(L) (See Figure 1)

Step 2. Once you have determined how many and the length of the ionization tubes, screw the tube(s) into the back of the ionizer while gently holding the grounding clip away from the tube.

Step 3. To mount the units in a duct:

- Trace a 5"x5" square on the surface of the duct onto which you are mounting the ionizer. The units have a gasket that forms a seal between the duct and the mounting plate.
- Cut out the traced portion of the duct using snips or sheet metal shears.
- Screw the model 100 or 200 onto the duct using sheet metal screws (See Figure 1).

Step 4. If the ionizer cannot be installed in the supply duct due to temperature limitations or it's not easily accessible for tube replacement, the ionizers can be mounted inside the AHU or RTU using an "L" shaped bracket available from many hardware suppliers. See Figure 2 for alternate locations. Be sure to select a location within the air handling unit where there is good airflow. One such location is immediately adjacent to the fan inlet.

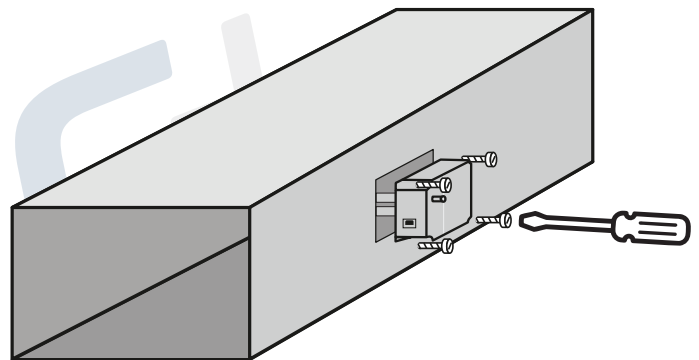

Figure 1

GENERAL MOUNTING LOCATION CRITERIA:

- There must be sufficient airflow over the tube(s).
- Do not mount the units before the filter.
- Do not mount downstream of a gas or oil-fired furnace.
- Avoid locations where moisture may be present like immediately downstream of a cooling coil.
- Vertical mounting of the tubes is preferred; horizontal tubes are acceptable.

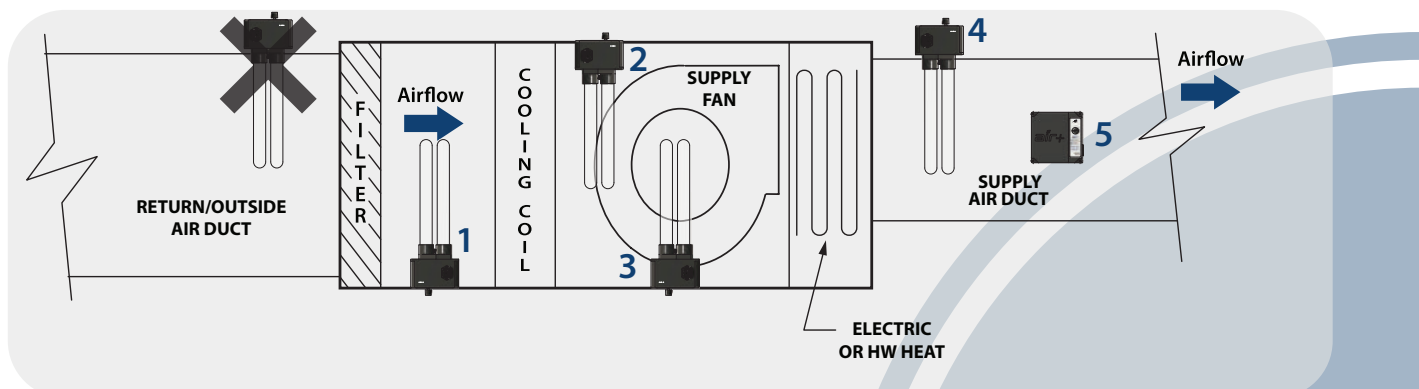

Figure 2

ELECTRICAL INSTALLATION

WARNING: The secondary voltage at the ionizing tubes can be 3,000 Volts AC. Do not connect to power before the installation is complete.

CAUTION: Always disconnect power to the unit before handling any of the unit components.

CAUTION: To reduce the risk of shock, the equipment has a grounding type plug with a grounding pin. This plug will only fit into a grounding type power outlet. If there isn't a proper power outlet, contact qualified personnel to install one. Do not alter the plug in any way.

- Step 1.** The Model 100 or 200 is available in three primary voltage models – 120 Volts AC (101 and 201), 230 Volts AC (Model 102 and 202) or 24V AC (Model 103). The units may be used on 50 or 60 Hz frequencies. Verify that the unit's voltage is the same as the available voltage by checking the label on the unit.
- Step 2.** The typical model 100 draws about 10 Watts and the 200 draws about 20 Watts. The power source should not be protected by a breaker exceeding 20 Amps.
- Step 3.** The unit should be powered only when there is airflow in the system. This can be accomplished by:
 - a) On single speed supply fan systems, using the fan's power supply. Match voltage to ionizer voltage.
 - b) Using a pressure differential switch in series with the unit's power supply.
 - c) Installing a relay off the 24 Volt fan control circuit and wiring the unit's power through the NO contacts.
 - d) Wiring to the "EAC" (Electronic Air Cleaner) contacts provided on many current AHU models.
 - e) On systems where the above fan interlocking options are not available, contact your Air+ Representative for an Air+Plate unit. This product is a mounting frame with an integral pressure differential switch that accepts 120V or 230V into its junction box.

OPERATION

The ionization control knob is a six-position switch that is used to turn the unit on and adjust the ionization output.

1. When the knob is in the "0" position, no power is being applied to the ionization tube and the blue LED is off. Rotating the knob from "0" to "1" through "5" turns the ionizer on and then increases the ionization output from about 50% to 100% and will illuminate the blue LED.
2. The ionization level is set by the installer and should not require adjustment unless pollutant levels change. Initial ionization level should be set to #3, but can be adjusted as necessary.
3. The benefit of the ionization system is only realized when the supply fan is running. So, to achieve improved air quality, run the fan continuously or use an IAQ type thermostat which will cycle the fan a few times per hour.

MAINTENANCE

WARNING: The secondary voltage to the ionizing tubes can be 3,000 Volts AC. Always disconnect power to the unit and switch the power to the "0" position before performing any maintenance.

Tubes are rated for between one (1) and two (2) years of service depending on the type of pollutant being treated, the filtration of the air handling system, and maintenance of the tubes. The tubes can be cleaned using the procedure below or you can contact your local Air+ Representative to purchase replacement tubes. (www.air-plus.com)

- Step 1.** Wearing protective gloves, carefully remove the tubes from the ionizer.
- Step 2.** Remove the outer mesh screen from the tube. You may need to carefully rotate the screen back and forth to loosen it first.
- Step 3.** Using soapy water or a commercially available cleaning solution, clean the outside of the glass tube and the wire mesh screen. Do not submerge the tube in water.
- Step 4.** Allow both components to dry completely before reinstalling the screen on the outside of the glass tube.
- Step 5.** Reinstall the tubes in the ionizer. Cleaning the tubes every 6 months will prolong the life of the tubes, but they won't last more than 3- 4 years regardless of this cleaning regimen.

TROUBLESHOOTING

If the ionizer is not operating properly, check that:

1. The unit is powered, and the adjustment knob is set from "1" to "5" and that the blue light illuminates.
2. The 0.5 Amp (Models 101, 201), 1.0 Amp (Models 102, 202) or 3.0 Amp (Models 103) glass cartridge slow blow fuse is not blown. The fuse is located under the power plug. The fuses are slow blow 5mm x 20mm rated at 250 Volts and are available at most electrical supply stores.
3. If the fuse is blown, disconnect power, remove the tube, and replace the fuse. Turn on power to the unit WITHOUT a tube installed. If the fuse blows again, return the unit to the Air+ Representative for factory service.
4. If the fuse does not blow, the problem is most likely a defective tube. Carefully inspect the tube for cracks and/or tiny air bubbles. Although rare, cracks are usually found at the capped end of the tube.
5. If the tube has been subjected to high temperatures, above 150° F, there is a possibility of a pin hole. These are difficult to spot but can cause shorting of the tube. Install the tube into the unit and power the unit with a new fuse. If the fuse blows, the tube is defective and requires replacement.
6. If the tubes are more than two years old, replace them.

OPTIMIZING SYSTEM PERFORMANCE FOR VARIOUS APPLICATIONS

In order to achieve the best performance from your ionization system, it is essential to provide an adequate level of ionization. This is particularly important in commercial and industrial settings, where various pollutants can originate from different sources. These sources could be airborne particles from cigarette smoke, wildfires, and pollen; volatile organic compounds (VOCs) emitted by cleaning products, glues, paints, and chemicals; unpleasant odors from locker rooms, cannabis grow facilities, garbage rooms, and industrial processes; and even health-related issues caused by airborne bacteria and viruses. Selecting the right equipment is crucial to fully harness the advantages of the ionization system.

Equipment Selection Chart			Airflow (CFM) Serving the Space					
			1,000	2,000	3,000	5,000	10,000	20,000
Pollutant Index	1	Residence with smokers, nursing home, populated arena, transportation hub	(1) 100C	(1) 100D	(1) 100E	(1) 200E	(1) 500F	(2) 500F
	2	Casino, bar/restaurant, locker room, food processing, animal hospital/kennel.	(1) 100D	(1) 100E	(1) 200E	(1) 500E	(2) 500E	(3) 500F
	3	Smoking casino, cannabis grow facility, nail/beauty salon, light manufacturing	(1) 100E	(1) 200D	(2) 200D	(1) 500F	(2) 500F	(4) 500F
	4	Industrial facility, heavy manufacturing, garbage room, loading dock area	(1) 200D	(1) 200E	(1) 500E	(2) 500E	(3) 500F	(6) 500F
	5	Heavily polluted area, unusually high odors, wastewater treatment plant	(1) 200E	(1) 500E	(1) 500F	(2) 500F	(4) 500F	(8) 500F

Notes:

1. If you require further assistance, please contact our support team at techsupport@air-plus.com.
2. Model 100 has (1) tube, 200 has (2) tubes, and 500 has (5) tubes.
3. The ionization control knob can be used to fine tune ion levels as needed.

