

# INSTALLATION, OPERATION, AND MAINTENANCE MANUAL

## 500 SERIES

(501E, 501F, 502E, 502F)



**air+**  
air-plus.com

©2023 Air+ Rev 10/23



## INTRODUCTION

The Air+ 500 series ion generators are 5-tube commercial quality equipment that can be installed in air handling units (AHU), roof top units (RTU) or duct systems for commercial and industrial applications. The units are effective in reducing harmful pathogens and odors by introducing positive and negative ions into the system airflow. The quantity of ionizers and length of the ionization tubes are dependent on the airflow in the system and the severity of the pollutants in question. See chart on the back of this manual for selection criteria.

## MECHANICAL INSTALLATION

**WARNING:** To reduce the risk of fire, this unit should not be installed downstream of a humidifier or exposed to other sources of moisture.

**CAUTION:** Do not install this product under a suspended floor or behind a structural wall, ceiling or floor.

**CAUTION:** This product should not be mounted in a location where the air temperature exceeds 150° F. This typically means that it should not be installed at the outlet of a gas or oil-fired furnace.

### GENERAL MOUNTING LOCATION CRITERIA:

- Ensure that the ionization tubes will receive sufficient airflow.
- Do not mount the units in the return air duct or before the system filter.
- Do not install immediately downstream of a humidifier.
- Allow sufficient space downstream of a cooling coil to avoid moisture carryover.

**Step 1.** After removing the ionizer from its shipping carton, ensure that there is no damage to any of the components.

**Step 2.** If the ionization tubes are not already installed, follow these instructions:

- a. The top middle tube should be installed first.
- b. Insert the tube into the angled bracket at the control panel end of the ionizer and secure using the supplied friction nuts.
- c. Lightly tighten the 4mm grounding clamp screws to ensure good contact with the tube's outer mesh screen. Don't overtighten.

**Step 3.** The units can either be installed inside an air handling unit or in the supply air duct. See Figure 1 for acceptable mounting locations.

**Step 4.** The ionization tubes should be installed parallel to the airflow, although perpendicular is also acceptable.

**Step 5.** If multiple units are required, install them in parallel, not in series. For example, install the units on top and bottom or left and right sides of a duct, not downstream of each other. Avoid the situation where ionized air from one unit passes over a second unit. See Figure 2.

**Step 6.** Units should be installed to allow access to the ionization control knob and for general maintenance.

**Step 7.** Mounting instructions:

- a. To mount the ionizer inside an air handling unit, use "L" or "Z" shaped brackets that are secured to the walls, floor or ceiling of the AHU. A mounting rack can be used for multiple ionizers. See Figure 1.
- b. To mount the units in a duct, cut a 19.5" x 9" rectangular hole in the duct for a 500E and a 26" x 9" hole for a 500F. Screw through the pre-drilled mounting holes into the duct using self-tapping sheet metal screws. The units have a gasketed flange that forms a seal between the duct and the ionizer.

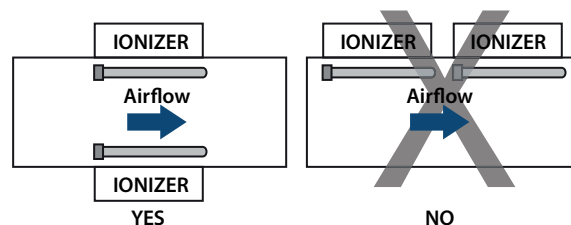
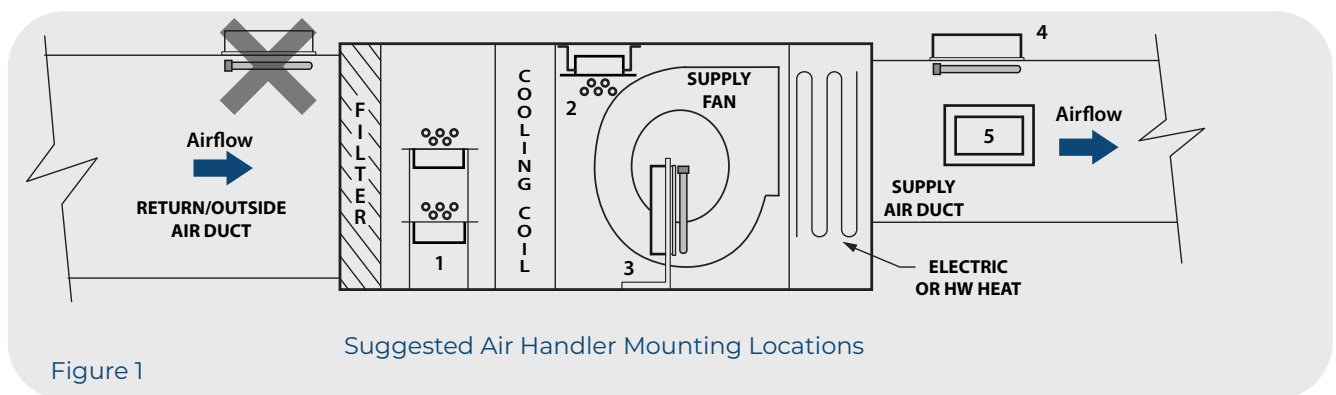

## ELECTRICAL INSTALLATION

**WARNING:** The secondary voltage to the ionization tubes can be 2,900 Volts AC. Do not connect to power before the installation is complete. Always disconnect power to the unit before handling any of the unit components.

1. The 500 Series ionizers are available in either 120V AC or 230V AC. The units may be used on 50 Hz or 60 Hz frequencies. Verify that the unit's voltage is the same as the available power.
2. 120V model 501E draws 35 Watts and 120V model 501F draws 50 Watts. The power source should not be protected by a breaker exceeding 20 Amps.
3. The unit should be powered only when there is airflow in the system. This can be accomplished by:
  - a) On single speed supply fan systems, using the fan's power supply. Match voltage to ionizer voltage.
  - b) Using a pressure differential switch in series with the unit's power supply.
  - c) Installing a relay off the 24 Volt fan control circuit and wiring the unit's power through the NO contacts.
  - d) Wiring to the "EAC" (Electronic Air Cleaner) contacts provided on many current AHU models.
4. A junction box should be installed within 4 feet of the unit. 3/8 inch flexible metal conduit (BX) or SO cord can be used to wire the ionizer (check with the local Authority Having Jurisdiction (AHJ)). Figure 3 shows the power inlet fitting detail.

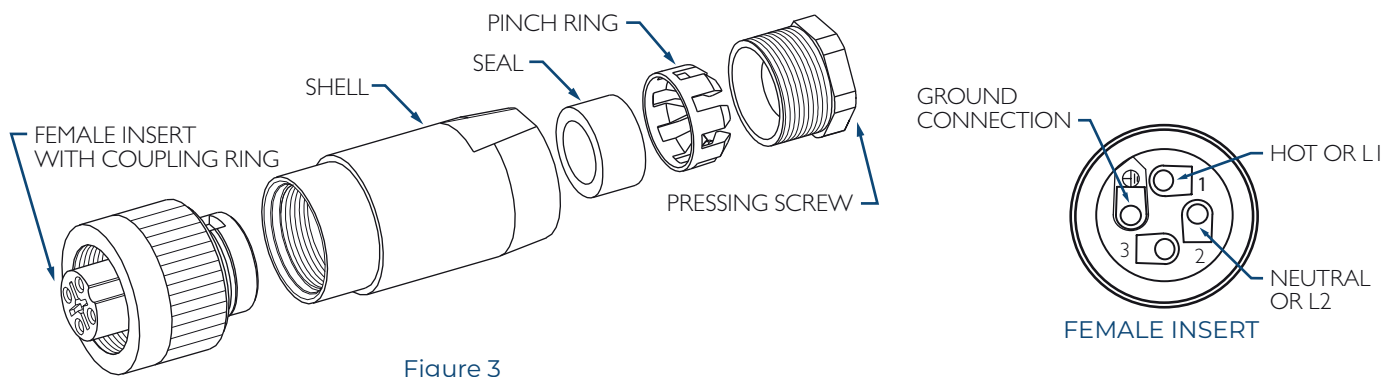

Figure 3

- Step 1. Trim the protective steel conduit of the BX cable exposing 1" - 1¼" of the internal wires.
- Step 2. Strip the wires exposing 3/8" copper.
- Step 3. Unscrew the Shell assembly from the Female Insert by pushing the Coupling Ring towards the Shell assembly and unscrewing counterclockwise.
- Step 4. Unscrew the Pressing Screw counterclockwise exposing the Pinch Ring and rubber Seal.
- Step 5. Slide the Pressing Screw, Pinch Ring, Seal, and Shell over the BX cable, ensuring that all pieces are in the right order and direction as shown above.
- Step 6. Insert the Hot or L1 (black) wire into the No. 1 hole on the Female Insert fitting. Insert the Neutral or L2 (white) wire into the No. 2 hole and the Ground wire into the ground hole. NOTE: Inserting all three wires at the same time makes the assembly process easier. Tighten the set screws securely.
- Step 7. Slide the Shell fitting towards the Female Insert fitting and screw together clockwise.
- Step 8. Ensure that the rubber Seal is sitting snugly inside the large end of the Pinch Ring.
- Step 9. Slide the Seal and Pinch Ring assembly and the Pressing Screw towards the Shell fitting.
- Step 10. Insert the Seal and Pinch Ring assembly into the Shell fitting and screw the Pressing Screw into the Shell fitting securing the BX cable tightly into the Shell assembly.
- Step 11. Plug the completed assembly into the male fitting on the ionization unit and screw the Coupling Ring clockwise to join the two fittings. The Female Insert will only fit onto the male fitting one way.

## OPERATION

1. Press the on/off switch to the "on" position. The green light over the switch will illuminate if power is connected to the unit.
2. The ionization control knob is a six-position switch that can be used to adjust the ionization output. When the knob is in the "0" position, no power is being applied to the ionization tubes and the red light will be off. Rotating the knob from "0" through "5" increases the ionization output and the red light illuminates.
3. The ionization level is set by the installer and does not require regular adjustment. The ionization level in the treated space should fall between 500 and 1500 ions/cm<sup>3</sup>. An ion meter can be used to measure the ionization level. Alternatively, the ionization level can be adjusted by the installer or the end user until the desired air quality is achieved.

## MAINTENANCE

**WARNING:** The secondary voltage to the ionizing tubes can be 2,900 Volts AC. Always disconnect power to the unit and switch the power to the “off” position before performing any maintenance.

1. The tubes are rated for 17,600 hours of operation but can vary depending on the type of pollutant treated, the quality of the upstream filtration, and the tube maintenance schedule. Contact your local Air+ representative to purchase replacement tubes.
2. This equipment requires very little maintenance, especially when the air in the system is properly filtered. On projects with heavily polluted air, the ionization tubes should be inspected and cleaned every six months or when necessary. Always wear gloves for personal protection when handling the tubes. To clean the tubes:
  - a. Remove the tubes from the unit by loosening the clamp screws and the lock nuts.
  - b. Slide the wire mesh outer “sock” off the outside of the tubes. Wash the sock in clean soapy water. Dry the sock thoroughly.
  - c. Clean the tube glass with soapy water or commercially available glass cleaner. Dry the tube thoroughly.
  - d. Replace the sock and reinstall the tubes. Install the top middle tube first.

## REMOTE MONITORING

1. The unit is equipped with a dry contact that will close when power is applied and open on loss of power. This dry contact can be connected to the building management system (BMS) to monitor the operation of the ionizer. The monitoring cable can be ordered separately. The brown and yellow wires should be used to connect to the BMS.
2. The circuit is rated for 10 amps at 230V AC. The monitoring connector is an RS-232 9-pin female.

## TROUBLESHOOTING

If the unit is not working, check in the following order that:

1. The power switch is in the “on” position and the green light illuminates.
2. The 1.0 Amp, glass cartridge fuse is not blown. The fuses are 5mm × 20mm rated at 250 volts and are available at any electrical supply store.
3. If the unit fuse is blown, remove all the tubes and replace the fuse. Turn the unit power on. If the fuse blows again, return the unit to the Representative for factory service.
4. If the fuse does not blow, the most likely problem is a cracked tube. Carefully inspect the tubes for cracks.
5. If the tube has been subjected to high temperatures, there is a possibility of a pin hole defect. These are difficult to spot but can cause shorting of the tube. Install tubes into the unit one at a time, powering the unit after each tube installation. If the fuse blows, the last tube installed is defective and should be replaced.
6. If there seems to be a loss of effectiveness, check the tubes and clean them if necessary. If the tubes are more than 2 years old, replace them.

## PRODUCT SELECTION

### OPTIMIZING SYSTEM PERFORMANCE FOR VARIOUS APPLICATIONS

An adequate level of ionization is vital for peak performance in commercial and industrial settings, addressing pollutants like airborne particles (from smoke, wildfires, and pollen), volatile organic compounds (from cleaning products, glues, paints, and chemicals), unpleasant odors (from locker rooms, cannabis grow facilities, and garbage rooms), as well as health-related concerns (airborne bacteria and viruses). Choosing the right equipment is crucial to maximize the benefits of the ionization system.

Equipment Selection Chart			Airflow (CFM) Serving the Space					
			1,000	2,000	3,000	5,000	10,000	20,000
Pollutant Index	1	Residence with smokers, nursing home, populated arena, transportation hub	(1) 100C	(1) 100D	(1) 100E	(1) 200E	(1) 500F	(2) 500F
	2	Casino, bar/restaurant, locker room, food processing, animal hospital/kennel.	(1) 100D	(1) 100E	(1) 200E	(1) 500E	(2) 500E	(3) 500F
	3	Smoking casino, cannabis grow facility, nail/beauty salon, light manufacturing	(1) 100E	(1) 200D	(2) 200D	(1) 500F	(2) 500F	(4) 500F
	4	Industrial facility, heavy manufacturing, garbage room, loading dock area	(1) 200D	(1) 200E	(1) 500E	(2) 500E	(3) 500F	(6) 500F
	5	Heavily polluted area, unusually high odors, wastewater treatment plant	(1) 200E	(1) 500E	(1) 500F	(2) 500F	(4) 500F	(8) 500F

